

## MKF-PJS01 Series

Mate Industrial Joystick, Hall / Potentiometer, Single Axis, Panel Mounted



### APPLICATION

Typical application on various electro-hydraulic control system of engineering vehicles and other electrical control system.

### DESCRIPTION

- Single-axis forward and backward directional or single directional operated
- Friction lock or spring return
- Center and start (end) position mechanical lock optional
- Hall and potentiometer is select-able
- Microswitch optional (maximum 10A@30Vdc)
- A variety of handle models can be configured

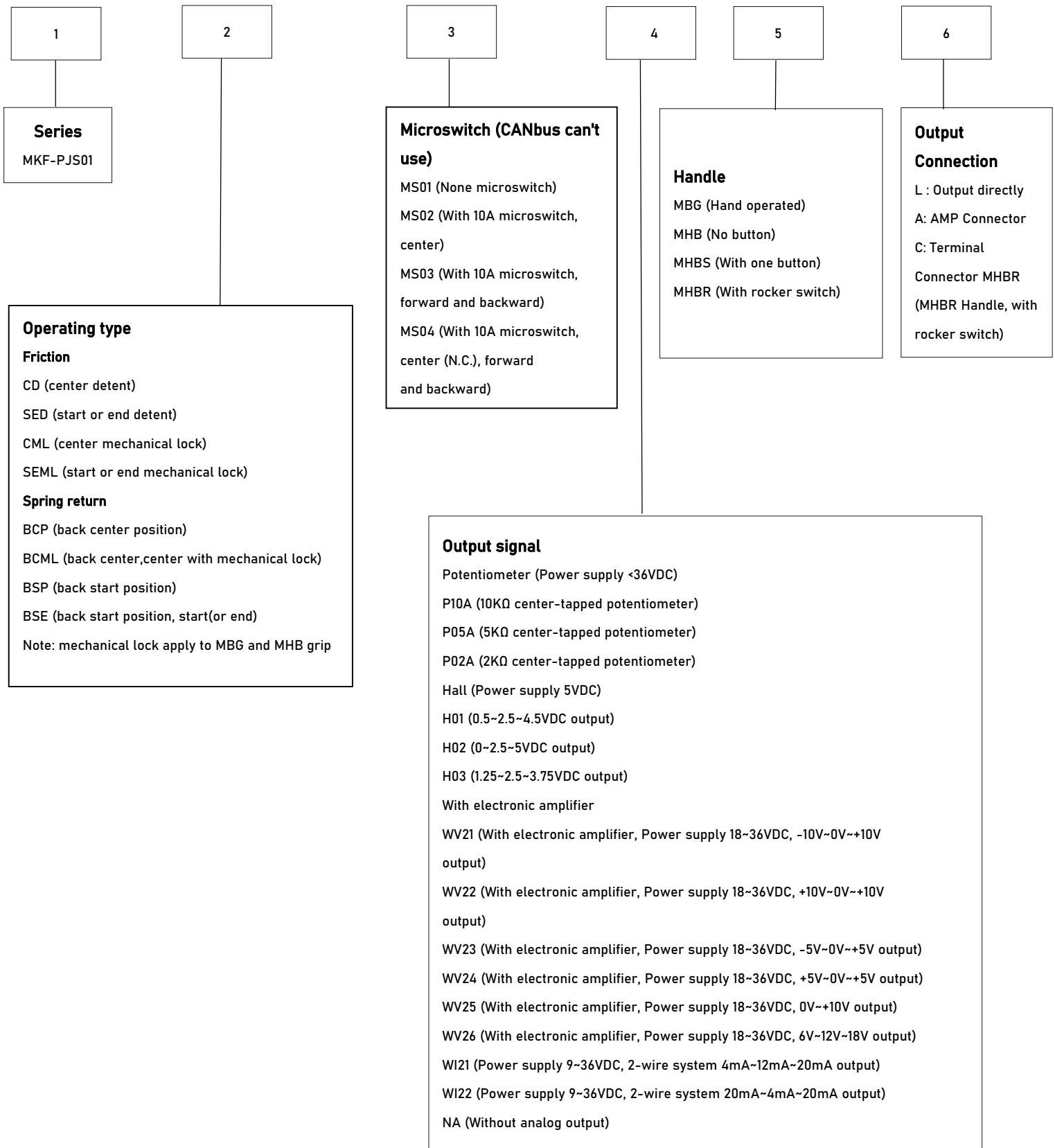

## Electrical Data

<b>Potentiometer</b>	
Power Supply Resistance	<36Vdc
Resistance	2KΩ, 5KΩ, 10KΩ
Center Angle	±3°
Maximum Dissipation	0.2W
<b>Hall</b>	
Power Supply	5±0.5Vdc
Supply Current	<11mA (Setting Power supply)
Maximum Allowable Overload Voltage	20Vdc
Reverse Maximum Allowance Voltage	-10Vdc
Output Linearity Tolerance	<±0.2V
<b>With electronic amplifier</b>	
Supply Voltage	18~36Vdc (U 21~U 25), 9~36Vdc (I 21~I 22)
Current Consumption	<20mA
Maximum Output Current	10mA(Standard power supply)
<b>Microswitch</b>	
Load Capacity	10A@30Vdc (Resistive load)
Expecting Life	5 million times (Mechanical), 200 thousand times (Electrical)
Insulation Resistance	>100MQ (500Vdc Insulating-resistance)
Breakout Angle	±5°

## Environmental Data

Operating Temperature	-30℃ ~+70℃
Storage Temperature	-40℃ ~+85℃
Protection Level	IP65 (Above the Panel)
Breakout Angle	±5°

## Mechanical Features

Travel Angle	±37.5°or 75°(single direction)
Operating Type	Spring return or Friction
Breakout Force	8N (spring) 16N (Friction)
Operating Force(max)	18N (spring) 16N (Friction)
Maximum Allowable Force	>260N
Expecting Life	>1 million cycles(potentiometer), >5million cycles (hall)
Weight	500g (without handle )

TECHNICAL DRAWINGS

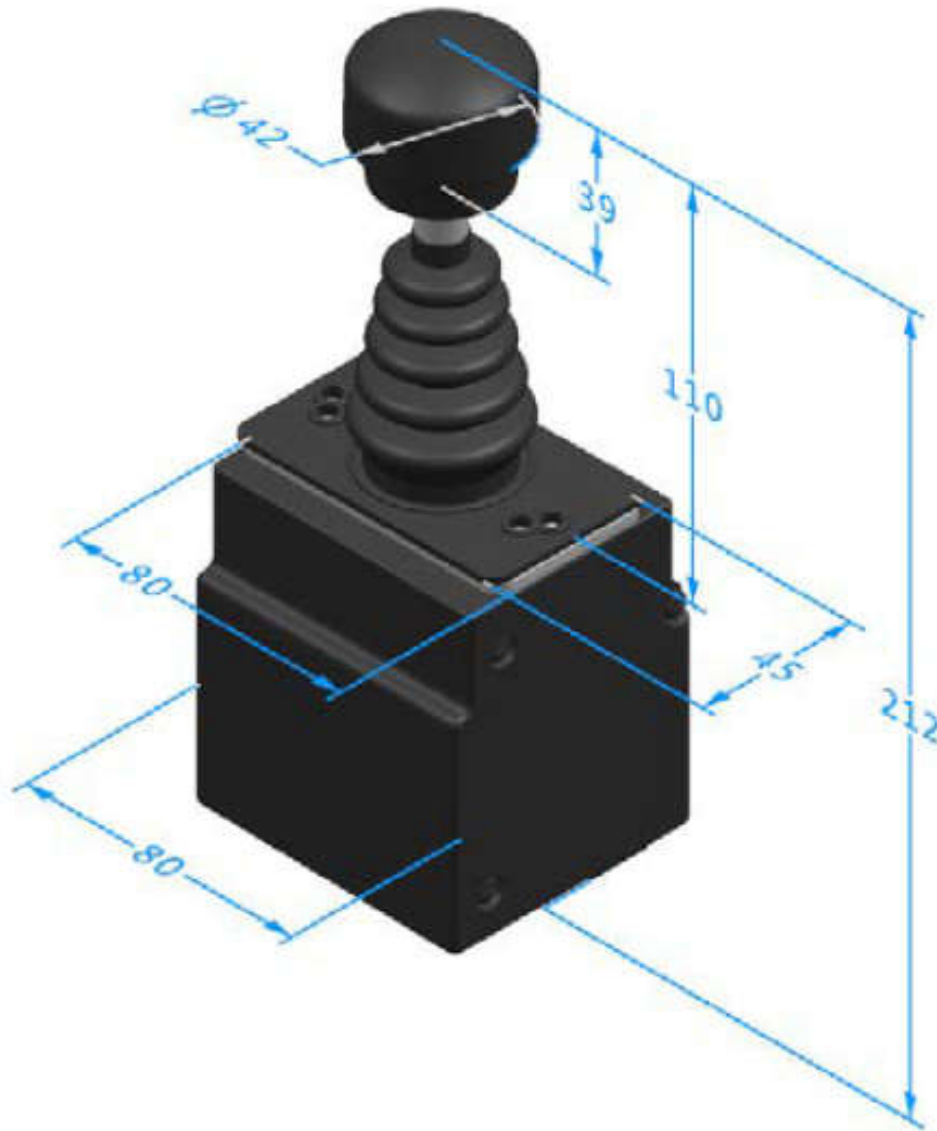

## Product Installation

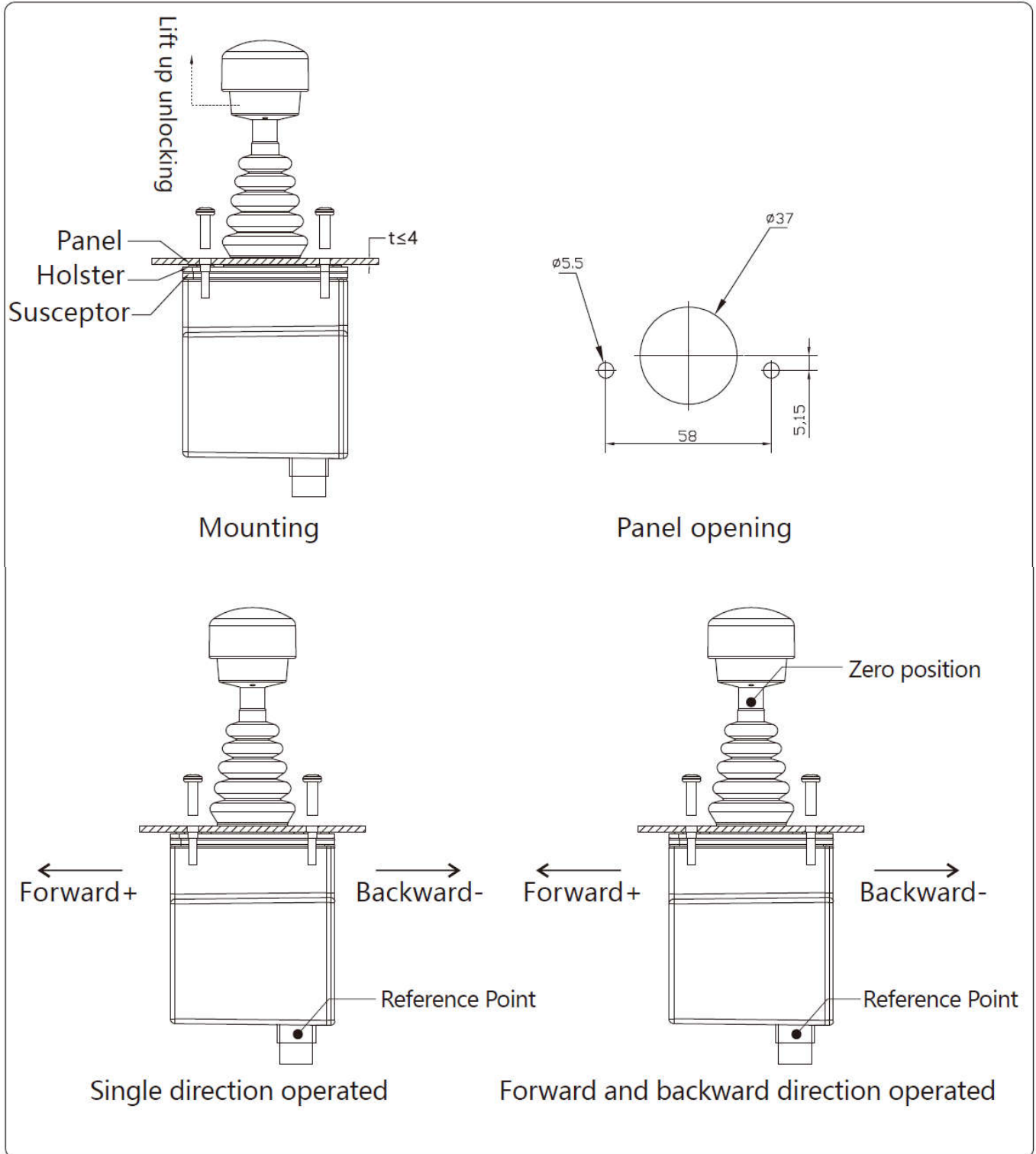

## Electrical Connections

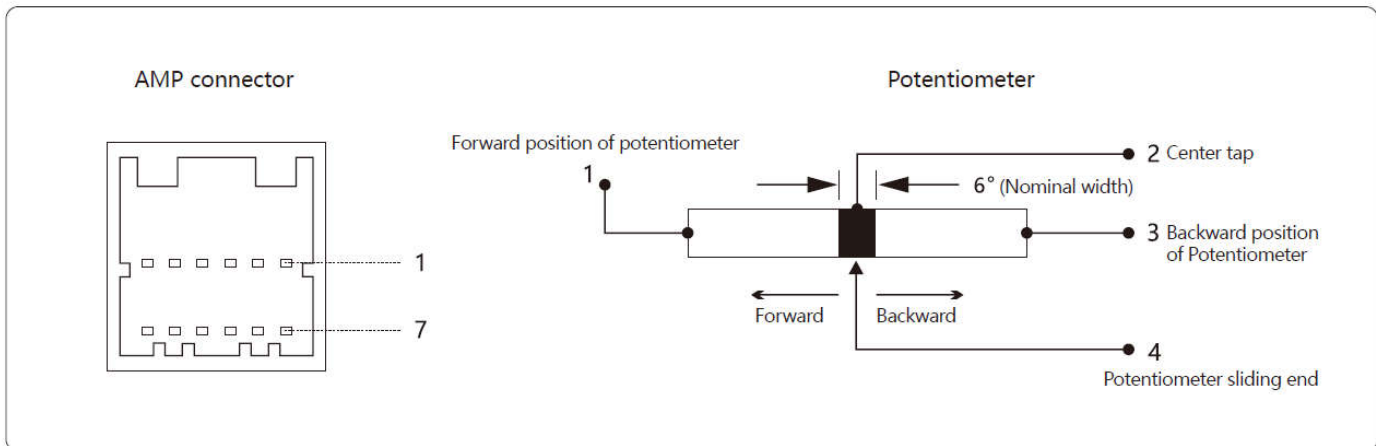

Pin	Pontentiometer	Hall	w/ electrical amplifier of output voltage	W/ electrical amplifier of output current
1	Potentiometer forward terminal	5VDC	Power Supply	
2	Potentiometer center tap	NA	GND	
3	Potentiometer Backward terminal	GND	Output positive (+)	NA
4	Pontentiometer sliding end	Output	Output positive (-)	NA
5	Directional switch forward(N.O) Start position switch of single direction(N.O)	Directional switch forward(N.O) Start position switch of single direction(N.O)	Directional switch forward(N.O) Start position switch of single direction(N.O)	Directional switch forward(N.O) Start position switch of single direction(N.O)
6	Forward directional switch common terminal Common terminal of start position	Forward directional switch common terminal Common terminal of start position	Forward directional switch common terminal Common terminal of start position	Forward directional switch common terminal Common terminal of start position
7	Directional switch backward(N.O) Single direction(N/A)	Directional switch backward(N.O) Single direction(N/A)	Directional switch backward(N.O) Single direction(N/A)	Directional switch backward(N.O) Single direction(N/A)
8	Backward directional common terminal Single direction(N/A)	Backward directional common terminal Single direction(N/A)	Backward directional common terminal Single direction(N/A)	Backward directional common terminal Single direction(N/A)
9	Rocker left directional(N.O)	Rocker left directional(N.O)	Rocker left directional(N.O)	Rocker left directional(N.O)
10	Handle of top switch common terminal	Handle of top switch common terminal	Handle of top switch common terminal	Handle of top switch common terminal
11	Rocker right directional(N.O)	Rocker right directional(N.O)	Rocker right directional(N.O)	Rocker right directional(N.O)

## Handle Optional

