

记号:	变更原因	签认	日期
-----	------	----	----

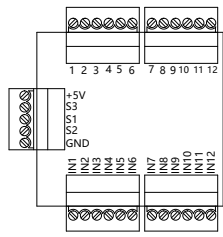
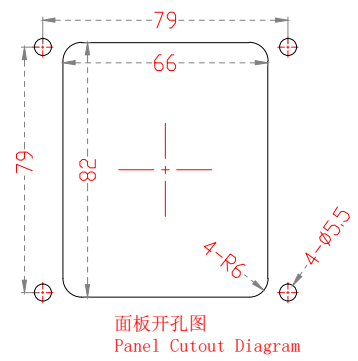
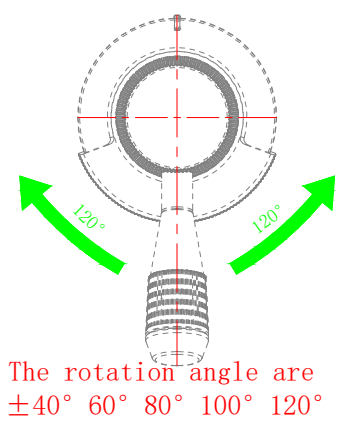
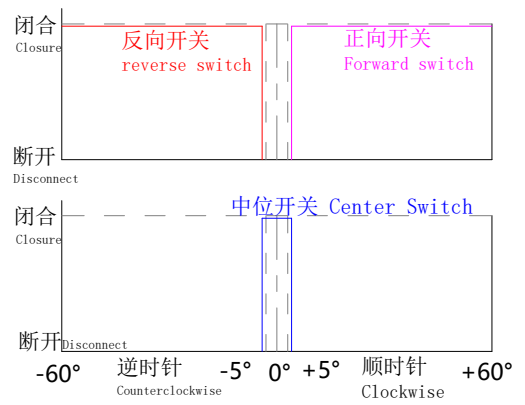
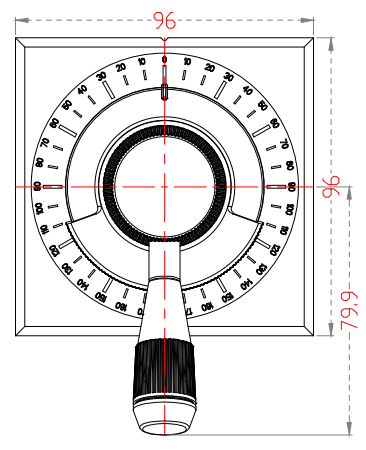
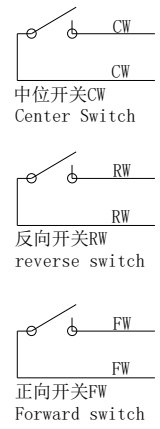
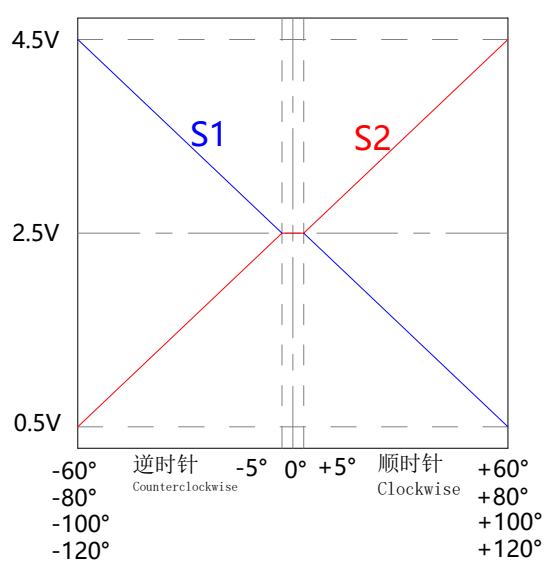
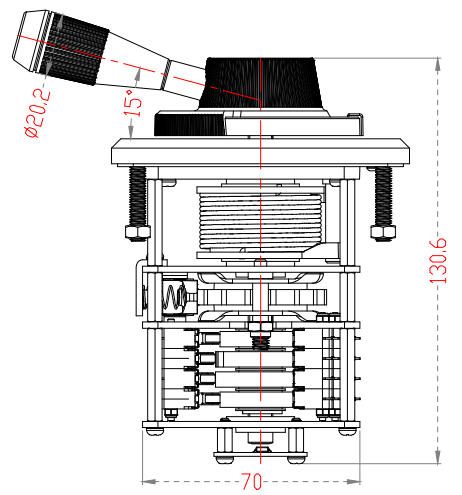
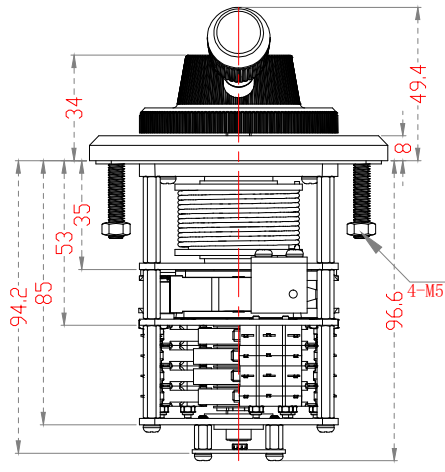
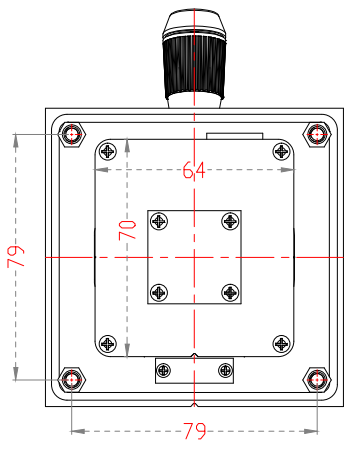

接线表Wiring Definition:
 +5V 电源+5V (Power +5V)
 S3 空 (Null)
 S1 信号输出1 (Signal 1 output)
 S2 信号输出2 (Signal 2 output)
 GND 电源0V (Power 0V)

- 接线表Wiring Definition:
- CW 中位开关 (Center switch)
 - CW 中位开关 (Center switch)
 - RW 反向开关 (Reverse switch)
 - RW 反向开关 (Reverse switch)
 - FW 正向开关 (Forward switch)
 - FW 正向开关 (Forward switch)
 - 空 (Null)
 - 空 (Null)
 - 空 (Null)
 - 空 (Null)
 - 空 (Null)
 - 空 (Null)
 - 空 (Null)

零件名称:	MKF-JS17
材料:	
数量:	
产品名称:	Joystick controller
3D图档名:	MKF-JS17
版本号:	01

选型:
 MKF-JS17系列,
 1, 弹簧回中, 中位有1档位振动感
 2, 摩擦定位多档位振动感: 22.5° / 档位
 1档位: 中位1个档位
 MKF-JS17 series,
 1, Spring returns, center detent
 2, Friction brake, positions detents: 22.5° / position
 1st position: Center position

Mate Technology Shenzhen Limited					
www.matend.com					
绘图:	1	2	比例:	1:1	视角:
设计:	1	2	阶段标记	单位:	mm
审核:	1	2			
批准:	1	2	第 3 页 共 3 页		