

Rev	Change Content	Change By	Date
01			
02			

A

A

B

B



C

C

D

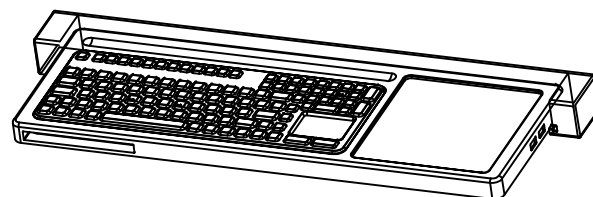
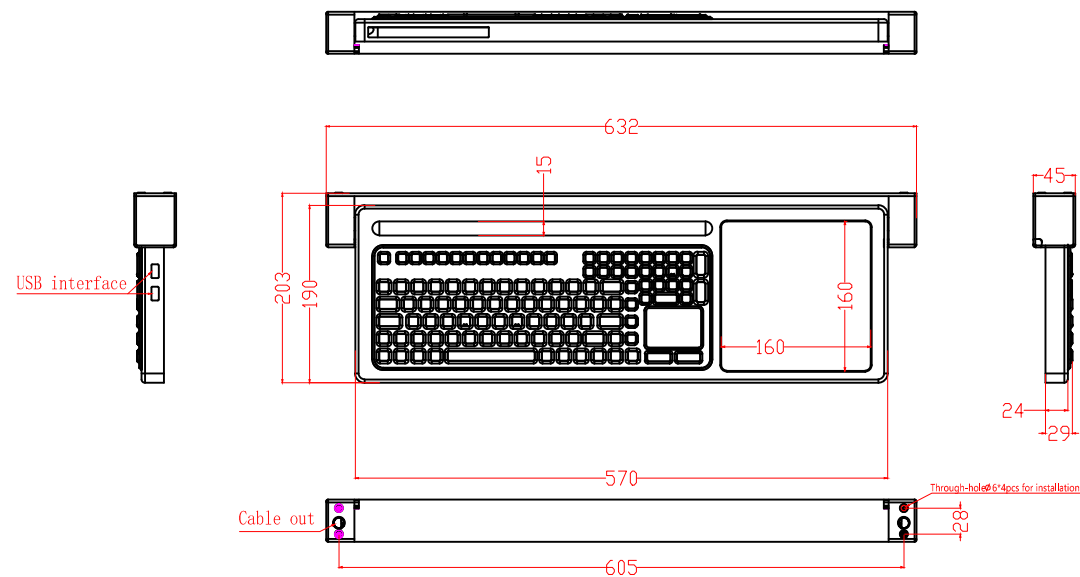
D



Product Name	Keyboard		Model No.	MKG-08
Designed By	Fan youlai	Date	2021.06.21	Material
Checked By		Date		Rev: 01
Tolerance: ±0.10		Drawing Width:		Unit: mm
 <b>MATE</b> <small>MADE BY PROFESSIONAL</small>		深圳市米拓实业有限公司 MATE TECHNOLOGY SHENZHEN LIMITED		 
				Page: 1 of 1

1

2

3

4

5

6